

Technical data sheet



Product features

Electric fryer 2 baskets 0,75 kW/l, 8+8 l on cabinet 400 V

Model	SAP Code	00006806
--------------	-----------------	----------



- Basin volume [l]: 8
- Drain type: Trough the cabinet
- Drain: Yes
- Maximum device temperature [°C]: 190
- Minimum device temperature [°C]: 50
- Material: Stainless steel
- Heating location: Inside the tank
- Number of baskets: 2
- Basket size [mm]: 2x 210 x 235 x 100

SAP Code	00006806	Basin volume [l]	8
Net Width [mm]	658	Number of basins	2
Net Depth [mm]	609	Number of baskets	2
Net Height [mm]	900	Basket size [mm]	2x 210 x 235 x 100
Net Weight [kg]	50.00	Ratio power/volume [kW/l]	0.75
Power electric [kW]	12.000	Production of fries [kg/h]	18
Loading	400 V / 3N - 50 Hz		

Technical data sheet



Technical drawing

Electric fryer 2 baskets 0,75 kW/l, 8+8 l on cabinet 400 V

Model

SAP Code

00006806

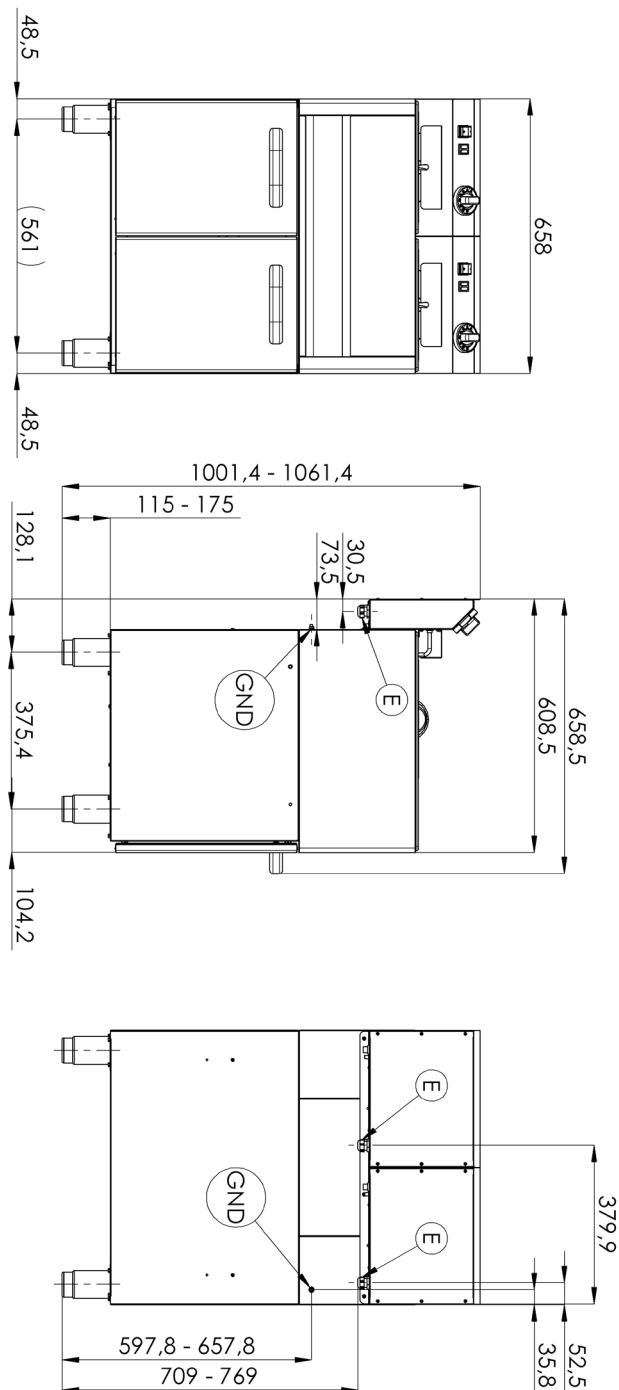

Electric fryer 2 baskets 0,75 kW/l, 8+8 l on cabinet 400 V

Model

SAP Code

00006806

1

All-stainless steel bathtub

long life
resistance of AISI 304 stainless steel material
the material does not cut

- savings on service interventions
- easier and faster operation

2

Degree of protection of the control elements IPX4

maintenance-free system
resistance to splash water
long life

- savings on service interventions
- easy cleaning and maintenance of equipment

3

Outlet into a removable collector in the base with a sieve against coarse dirt

outlet of the bath into the prepared container

- easy and safe handling

4

Cold zone

prevents food residues from burning
there is no change in the taste of the oil

- longer oil life
- easy access and maintenance

5

Removable heating element

longer lifetime
easy access

- fully removable electric box with heating element for convenient cleaning and servicing
- easy access even to corners and time saving

6

Higher rear chimney

prevention of spontaneous combustion

- safer heat dissipation and separation of oil and ventilation from the fryer

7

2 thermostats

safety and working thermostat

- traffic safety
- prevention of spontaneous combustion
- Prevention of oil flashover

Technical data sheet



Technical parameters

Electric fryer 2 baskets 0,75 kW/l, 8+8 l on cabinet 400 V

Model

SAP Code

00006806

1. SAP Code:

00006806

2. Net Width [mm]:

658

3. Net Depth [mm]:

609

4. Net Height [mm]:

900

5. Net Weight [kg]:

50.00

6. Gross Width [mm]:

705

7. Gross depth [mm]:

725

8. Gross Height [mm]:

1120

9. Gross Weight [kg]:

62.00

10. Device type:

Electric unit

11. Construction type of device:

With substructure

12. Power electric [kW]:

12.000

13. Loading:

400 V / 3N - 50 Hz

14. Protection of controls:

IPX4

15. Material:

Stainless steel

16. Indicators:

operation and warm-up

17. Worktop material:

AISI 304

18. Worktop Thickness [mm]:

0.80

19. Standard equipment for device:

lid and basket

20. Basin volume [l]:

8

21. Maximum device temperature [°C]:

190

22. Minimum device temperature [°C]:

50

23. Safety thermostat up to x ° C:

235

24. Adjustable feet:

Yes

25. Heating element material:

AISI 304

26. Number of baskets:

2

27. Number of basins:

2

28. Basket size [mm]:

2x 210 x 235 x 100

Technical data sheet



Technical parameters

Electric fryer 2 baskets 0,75 kW/l, 8+8 l on cabinet 400 V

Model

SAP Code

00006806

29. Basin material:

AISI 304 - High quality stainless steel

30. Ratio power/volume [kW/l]:

0.75

31. Production of fries [kg/h]:

18

32. Heating element construction:

Large surface area coiled heating element for extended service life and even heating of the oil bath

33. Drain type:

Trough the cabinet

34. Drain:

Yes

35. Heating location:

Inside the tank

36. Cross-section of conductors CU [mm²]:

4

- Výkon (kW): 30-37 (230 V); 53-64 (400 V)